

RC4156/RC4157

High Performance Quad Operational Amplifiers

Features

- Unity gain bandwidth for RC4156 – 3.5 MHz
- Unity gain bandwidth for RC4157 – 19 MHz
- High slew rate for RC4156 – 1.6 V/μS
- High slew rate for RC4157 – 8.0V/μS
- Low noise voltage – 1.4 μVRMS
- Indefinite short circuit protection
- No crossover distortion

Description

The RC4156 and RC4157 are monolithic integrated circuits, consisting of four independent high performance operational amplifiers constructed with an advanced epitaxial process.

These amplifiers feature improved AC performance which far exceeds that of the 741 type amplifiers. Also featured are

excellent input characteristics and low noise, making this device the optimum choice for audio, active filter and instrumentation applications. The RC4157 is a decompensated version of the RC4156 and is AC stable in gain configurations of -5 or greater.

Block Diagram

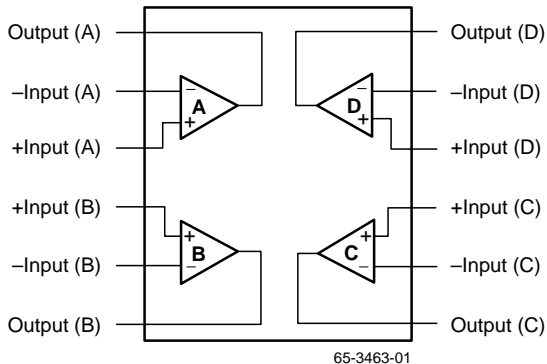

Pin Assignments

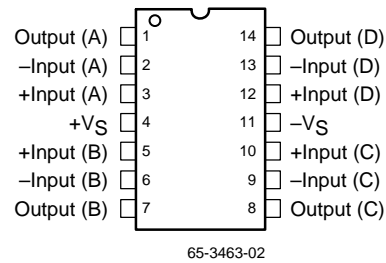

Absolute Maximum Ratings

(beyond which the device may be damaged)¹

Parameter		Min	Typ	Max	Units
Supply Voltage				±20	V
Input Voltage ²				±15	V
Differential Input Voltage				30	V
Output Short Circuit Duration ³		Indefinite			
PDTA < 50°C	SOIC			300	mW
	PDIP			468	mW
	CerDIP			1042	mW
Operating Temperature	RC4156/RC4157	0		70	°C
	RM4156/RM4157	-55		+125	°C
Storage Temperature		-65		150	°C
Junction Temperature	SOIC, PDIP			125	°C
	CerDIP			175	°C
Lead Soldering Temperature (60 seconds)	DIP			300	°C
	SOIC			260	°C
For T _A > 50°C Derate at	SOIC		5.0		mW/°C
	PDIP		6.25		mW/°C
	CerDIP		8.38		mW/°C

Notes:

- Functional operation under any of these conditions is NOT implied. Performance and reliability are guaranteed only if Operating Conditions are not exceeded.
- For supply voltages less than ±15V, the absolute maximum input voltage is equal to the supply voltage.
- Short circuit to ground on one amplifier only.

Operating Conditions

Parameter		Min	Typ	Max	Units
θ _{JC}	Thermal resistance		60		°C/W
θ _{JA}	Thermal resistance	SOIC		200	°C/W
		PDIP		160	°C/W
		CerDIP		120	°C/W

Electrical Characteristics

(V_S = ±15V, R_M = -55°C ≤ T_A ≤ +125°C, R_C = 0°C ≤ T_A ≤ +70°C)

Parameters	Test Conditions	RM4156/4157			RC4156/4157			Units
		Min	Typ	Max	Min	Typ	Max	
Input Offset Voltage	R _S ≤ 10 kΩ			5.0			6.5	mV
Input Offset Current				75			100	nA
Input Bias Current				320			400	nA
Large Signal Voltage Gain	R _L ≥ 2 kΩ, V _{OUT} ±10V	25			15			V/mV
Output Voltage Swing	R _L ≥ 2 kΩ	±10			±10			V
Supply Current			10			10		mA
Average Input Offset Voltage Drift			5.0			5.0		μV/°C

Electrical Characteristics

($V_S = \pm 15V$ and $T_A = +25^\circ C$ unless otherwise noted)

Parameters	Test Conditions	RM4156/4157			RC4156/4157			Units
		Min	Typ	Max	Min	Typ	Max	
Input Offset Voltage	$R_S \leq 10\text{ k}\Omega$		0.5	3.0		1.0	5.0	mV
Input Offset Current			15	30		30	50	nA
Input Bias Current			60	200		60	300	nA
Input Resistance			0.5			0.5		M Ω
Large Signal Voltage Gain	$R_L \geq 2\text{ k}\Omega$, $V_{OUT} \pm 10V$	50	100		25	100		V/mV
Output Voltage Swing	$R_L \geq 10\text{ k}\Omega$	± 12	± 14		± 12	± 14		V
	$R_L \geq 2\text{ k}\Omega$	± 10	± 13		± 10	± 13		V
Input Voltage Range		± 12	± 14		± 12	± 14		V
Output Resistance			230			230		Ω
Short Circuit Current			25			25		mA
Common Mode Rejection Ratio	$R_S \leq 10\text{ k}\Omega$	80			80			dB
Power Supply Rejection Ratio	$R_S \leq 10\text{ k}\Omega$	80			80			dB
Supply Current (All Amplifiers)	$R_L = \infty$		4.5	5.0		5.0	7.0	mA
Transient Response (4156)								
Rise Time			60			60		nS
Overshoot			25			25		%
Slew Rate		1.3	1.6		1.3	1.6		V/ μ S
Unity Gain Bandwidth (4156)		2.8	3.5		2.8	3.5		MHz
Phase Margin (4156)	$R_L = 2\text{ k}\Omega$, $C_L = 50\text{ pF}$		50			50		%
Transient Response (4157)	$A_V = -5$							
Rise Time			50			50		nS
Overshoot			25			25		%
Slew Rate		6.5	8.0		6.5	8.0		V/ μ S
Unity Gain Bandwidth (4157)	$A_V = -5$	15	19		15	19		MHz
Phase Margin (4157)	$A_V = -5$, $R_L = 2\text{ k}\Omega$, $C_L = 50\text{ pF}$		50			50		%
Power Bandwidth	$V_{OUT} = 20V_{p-p}$	20	25		20	25		kHz
Input Noise Voltage ¹	$F = 20\text{ Hz to } 20\text{ kHz}$		1.4	5.0		1.4	5.0	μ V _{RMS}
Input Noise Current	$F = 20\text{ Hz to } 20\text{ kHz}$		15			15		pA _{RMS}
Channel Separation			108			108		dB

Note:

1. Sample tested only.

Typical Performance Characteristics

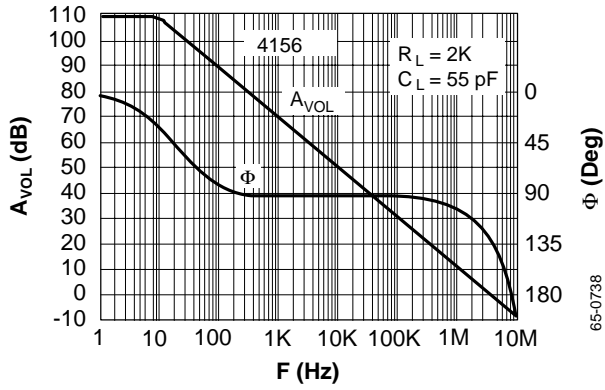

Figure 1. Open Loop Gain, Phase vs. Frequency

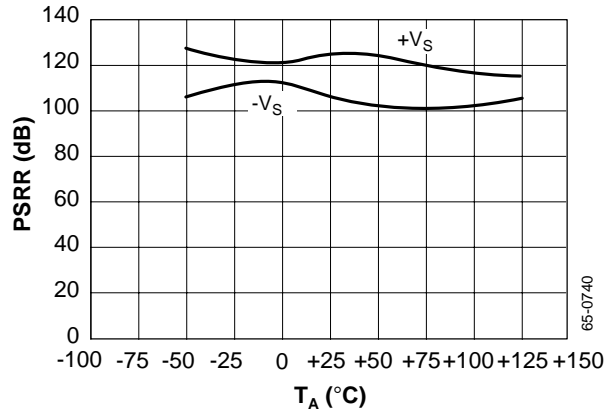

Figure 2. PSRR vs. Temperature

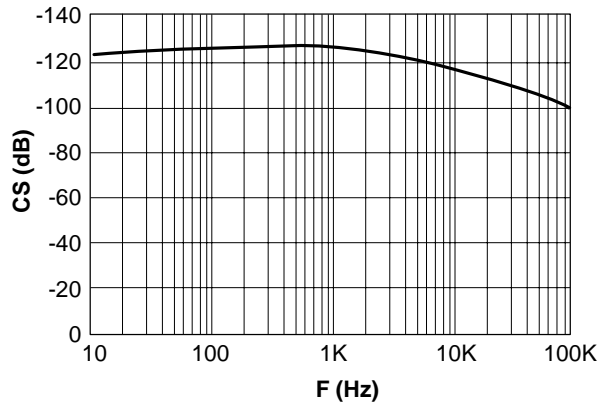

Figure 3. Channel Separation vs. Frequency

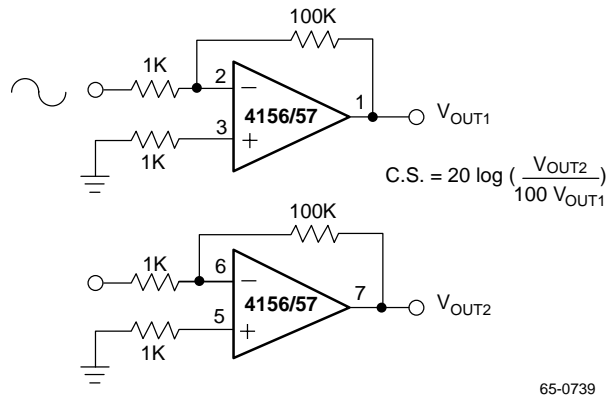

Figure 4. Transient Response vs. Temperature

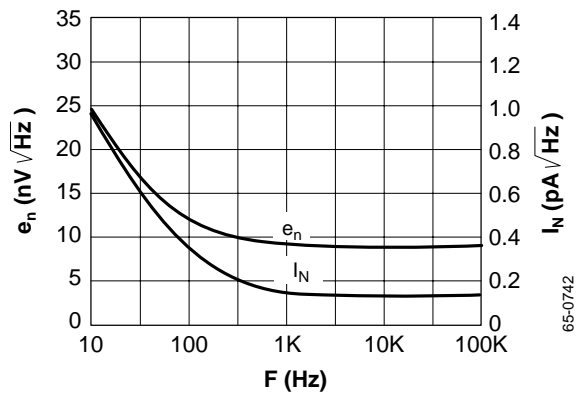

Figure 5. Input Noise Voltage, Current Density vs. Frequency

Typical Performance Characteristics (continued)

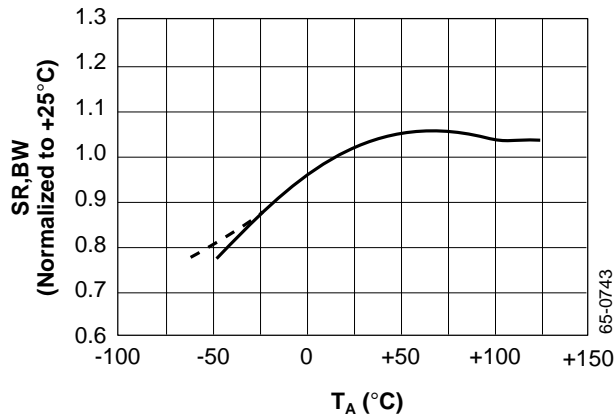

Figure 6. Slew Rate, Bandwidth vs. Temperature

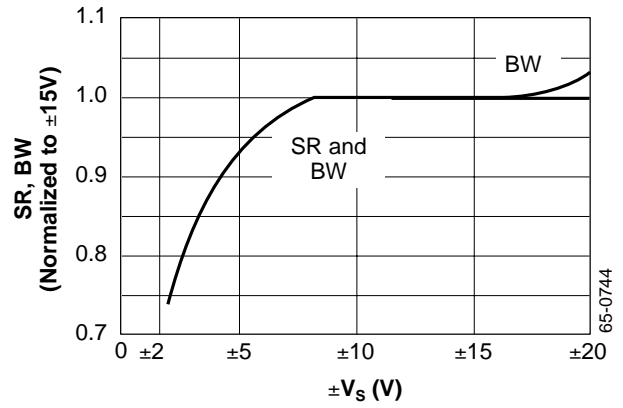

Figure 7. Slew Rate, Bandwidth vs. Supply Voltage

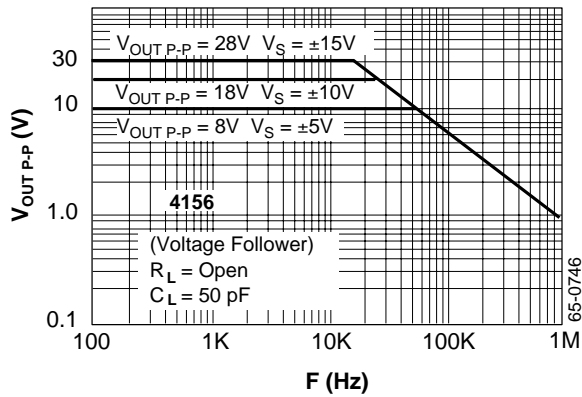

Figure 8. Output Voltage Swing vs. Frequency

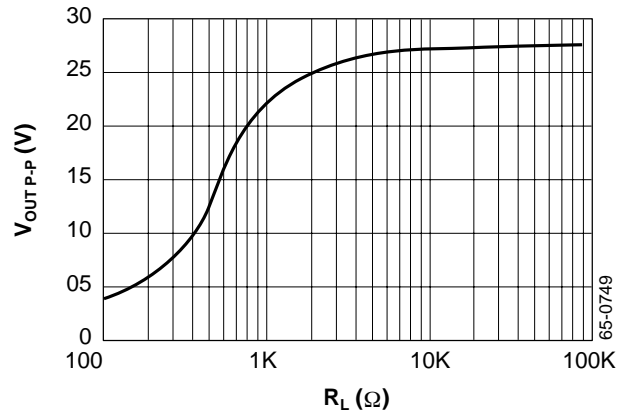

Figure 9. Output Voltage Swing vs. Load Resistance

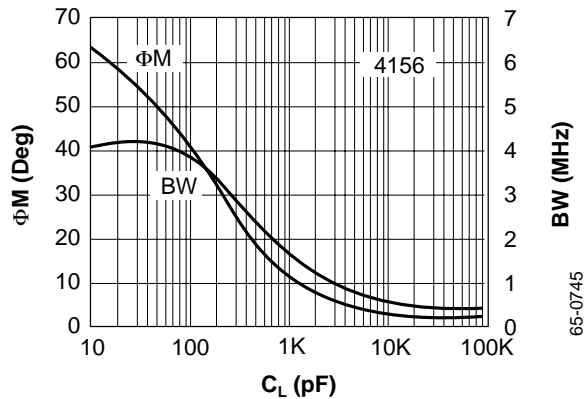

Figure 10. Small Signal Phase Margin, Unity Gain Bandwidth vs. Load Capacitance

Typical Performance Characteristics (continued)

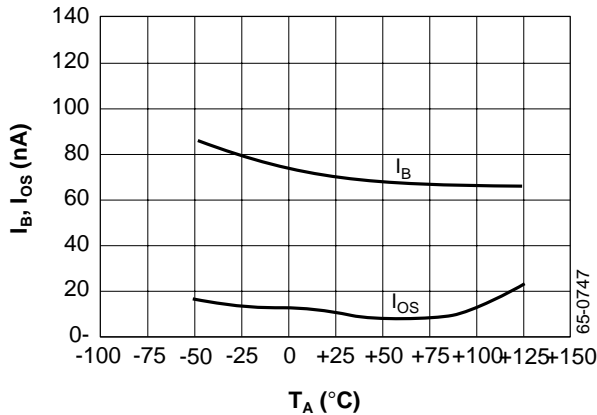

Figure 11. Input Bias, Offset Current vs. Temperature

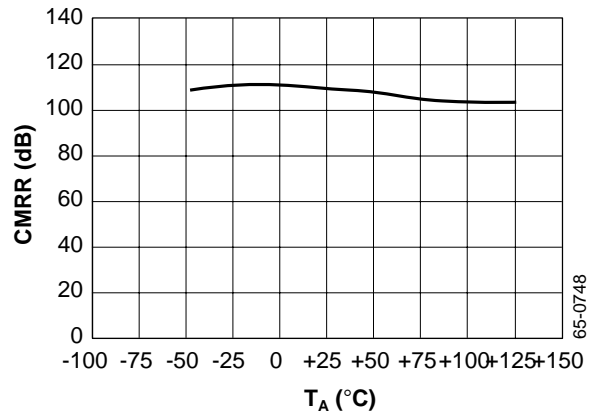

Figure 12. CMRR vs. Temperature

Applications

The RC4156 and RC4157 quad operational amplifiers can be used in almost any 741 application and will provide superior performance. The higher unity gain bandwidth and slew rate make it ideal for applications requiring good frequency response, such as active filter circuits, oscillators and audio amplifiers.

The following applications have been selected to illustrate the advantages of using the Fairchild Semiconductor RC4156 and RC4157 quad operational amplifiers.

Triangle and Square Wave Generator

The circuit of Figure 13 uses a positive feedback loop closed around a combined comparator and integrator. When power is applied the output of the comparator will switch to one of two states, to the maximum positive or maximum negative voltage. This applies a peak input signal to the integrator, and the integrator output will ramp either down or up, opposite of the input signal. When the integrator output (which is connected to the comparator input) reaches a threshold set by R1 and R2, the comparator will switch to the opposite polarity. This cycle will repeat endlessly, the integrator charging

positive then negative, and the comparator switching in a square wave fashion.

The amplitude of V₂ is adjusted by varying R1. For best operation, it is recommended that R1 and VR be set to obtain a triangle wave at V₂ with ±12V amplitude. This will then allow A3 and A4 to be used for independent adjustment of output-offset and amplitude over a wide range.

The triangle wave frequency is set by C0, R0, and the maximum output voltages of the comparator. A more symmetrical waveform can be generated by adding a back-to-back Zener diode pair as shown in Figure 14.

An asymmetric triangle wave is needed in some applications. Adding diodes as shown by the dashed lines is a way to vary the positive and negative slopes independently.

The frequency range can be very wide and the circuit will function well up to about 10 kHz. The square wave transition time at V₁ is less than 21 μs when using the RC4156.

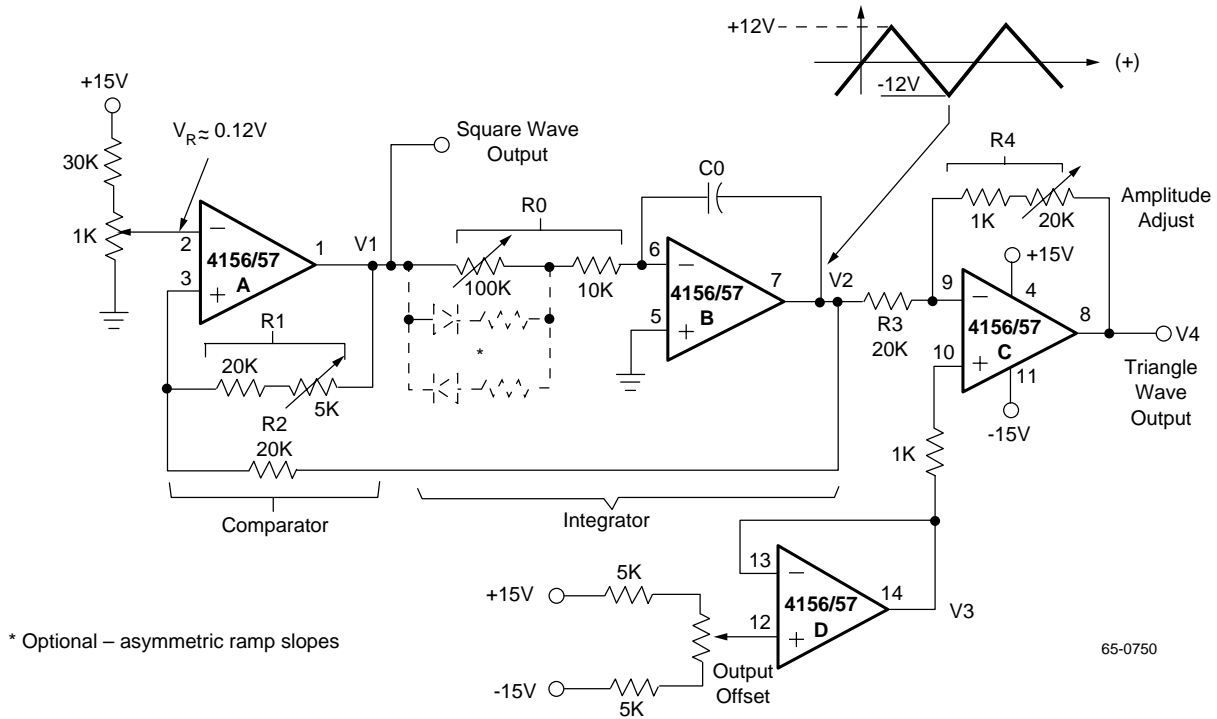

Figure 13. Triangle and Square Wave Generator

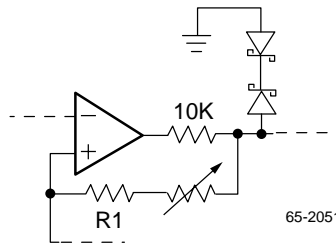

Figure 14. Triangle Generator—Symmetrical Output Option

Active Filters

The introduction of low-cost quad op amps has had a strong impact on active filter design. The complex multiple-feedback, single op amp filter circuits have been rendered obsolete for most applications. State-variable active-filter circuits using three to four op amps per section offer many advantages over the single op amp circuits. They are relatively insensitive to the passive-component tolerances and variations. The Q, gain, and natural frequency can be independently adjusted. Hybrid construction is very practical because resistor and capacitor values are relatively low and the filter parameters are determined by resistance ratios rather than by single resistors. A generalized circuit diagram of the 2-pole state-variable active filter is shown in Figure 15. The particular input connections and component-values can be calculated for specific applications. An important feature of the state-variable filter is that it can be inverting or non-inverting and can simultaneously provide three outputs:

lowpass, bandpass, and highpass. A notch filter can be realized by adding one summing op amp.

The RC4156 was designed and characterized for use in active filter circuits. Frequency response is fully specified with minimum values for unity-gain bandwidth, slew-rate, and full-power response. Maximum noise is specified.

Output swing is excellent with no distortion or clipping. The RC4156 provides full, undistorted response up to 20 kHz and is ideal for use in high-performance audio and telecommunication equipment.

In the state-variable filter circuit, one amplifier performs a summing function and the other two act as integrators. The choice of passive component values is arbitrary, but must be consistent with the amplifier operating range and input signal

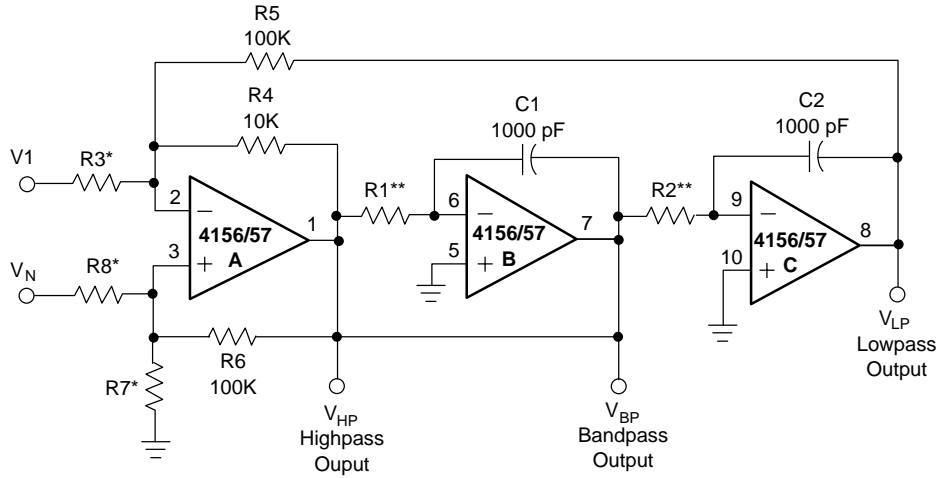

* Input connections are chosen for inverting or non-inverting response. Values of R3,R7,R8 determine gain and Q.

** Values of R1 and R2 determine natural frequency.

65-0751

Figure 15. 2-Pole State-Variable Active Filter

characteristics. The values shown for C1, C2, R4, R5 and R6 are arbitrary. Pre-selecting their values will simplify the filter tuning procedures, but other values can be used if necessary.

The generalized transfer function for the state-variable active filter is:

$$T(s) = \frac{a_2s^2 + a_1s + a_0}{s^2 + b_1s + b_0}$$

Filter response is conventionally described in terms of a natural frequency ω_0 in radians/sec, and Q, the quality of the complex pole pair. The filter parameters ω_0 and Q relate to the coefficients in T(s) as:

$$\omega_0 = \sqrt{b_0} \text{ and } Q = \frac{\omega_0}{b_1}$$

The input configuration determines the polarity (inverting or non-inverting), and the output selection determines the type of filter response (lowpass, bandpass, or highpass).

Notch and all-pass configurations can be implemented by adding another summing amplifier.

Bandpass filters are of particular importance in audio and telecommunication equipment. A design approach to bandpass filters will be shown as an example of the state-variable configuration.

Design Example Bandpass Filter

For the bandpass active filter (Figure 16) the input signal is applied through R3 to the inverting input of the summing amplifier and the output is taken from the first integrator (VBP). The summing amplifier will maintain equal voltage at the inverting and non-inverting inputs (see Equation 1).

$$\frac{R3R5}{R4 + \frac{R3R5}{R3 + R5}} V_{HP}(s) + \frac{R3R4}{R5 + \frac{R3R4}{R3 + R4}} V_{LP}(s) + \frac{R4R5}{R3 + \frac{R4R5}{R4 + R5}} V_{IN}(s) + \frac{R7}{R6 + R7} V_{BP}(s)$$

Equation 1.

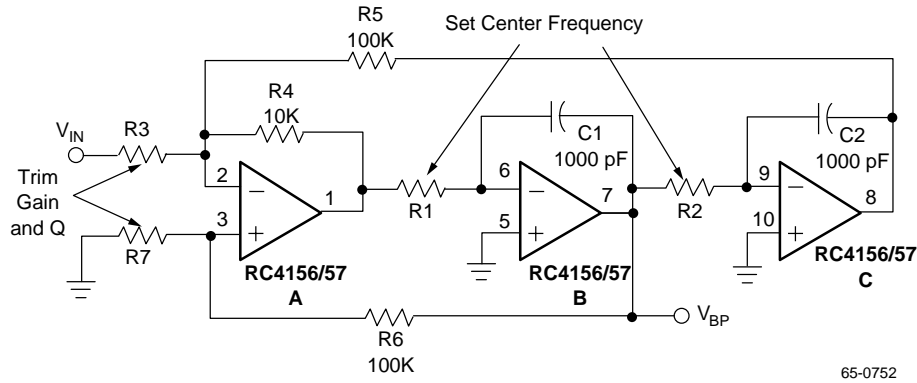

Figure 16. Bandpass Active Filter

These equations can be combined to obtain the transfer function:

$$V_{BP}(s) = -\frac{1}{R1C1S}V_{HP}(s) \quad \text{and} \quad V_{LP}(s) = -\frac{1}{R2C2S}V_{BP}(s)$$

$$\frac{V_{BP}(s)}{V_{IN}(s)} = \frac{\frac{R4}{R3} \cdot \frac{1}{R1C1}S}{S^2 + \frac{R7}{R6+R7} \left(1 + \frac{R4}{R5} + \frac{R4}{R3}\right) \left(\frac{1}{R1C1}\right)S + \left(\frac{R4}{R5}\right) \left(\frac{1}{R1C1R2C2}\right)}$$

Defining $1/R1C1$ as ω_1 , $1/R2C2$ as ω_2 , and substituting in the assigned values for $R4$, $R5$, and $R6$, then the transfer function simplifies to:

$$\frac{V_{BP}(s)}{V_{IN}(s)} = \frac{\frac{10^4}{R3} \cdot \omega_1 s}{S^2 + \left[\frac{1.1 + \frac{10^4}{R3}}{1 + \frac{10^5}{R7}} \right] \omega_1 s + \frac{1}{\omega_1 \omega_2}}$$

This is now in a convenient form to look at the center-frequency ω_0 and filter Q .

$$\omega_0 = \sqrt{0.1\omega_1\omega_2}$$

$$\omega_0 = 10^{-9} \sqrt{0.1R1R2} \quad \text{and}$$

$$Q = \left[\frac{1 + \frac{10^5}{R7}}{1.1 + \frac{10^4}{R3}} \right] \omega_0$$

The frequency responses for various values of Q are shown in Figure 17.

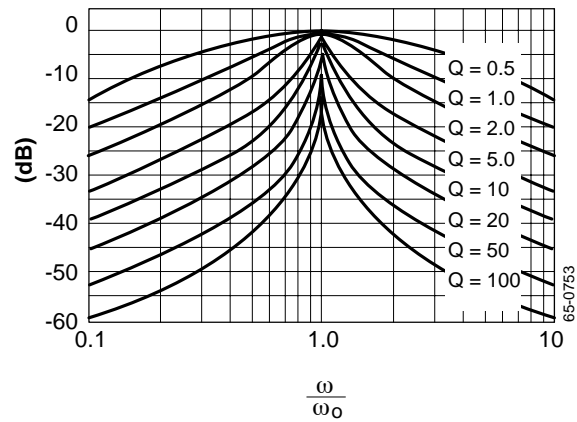

$$\frac{V_{BP}}{V_{IN}} = \frac{\frac{\omega}{\omega_0} \frac{1}{Q}}{\sqrt{\left[1 - \left(\frac{\omega}{\omega_0}\right)^2\right]^2 + \left(\frac{1}{Q} \frac{\omega}{\omega_0}\right)^2}}$$

Figure 17. Bandpass Transfer Characteristics Normalized for Unity Gain and Frequency

These equations suggest a tuning sequence where ω is first trimmed via R1 or R2, then Q is trimmed by varying R7 and/or R3. An important advantage of the state-variable bandpass filter is that Q can be varied without affecting center frequency ω_0 .

This analysis has assumed ideal op amps operating within their linear range, which is a valid design approach for a reasonable range of ω_0 and Q. At extremes of ω_0 and at high values of Q, the op amp parameters become significant. A rigorous analysis is very complex, but some factors are particularly important in designing active filters.

1. The passive component values should be chosen such that all op amps are operating within their linear region for the anticipated range of input signals. Slew rate, output current rating, and common-mode input range must be considered. For the integrators, the current through the feedback capacitor ($I = C \text{ dV/dt}$) should be included in the output current computations.

2. From the equation for Q, it should seem that infinite Q could be obtained by making R7 zero. But as R7 is made small, the Q becomes limited by the op amp gain at the frequency of interest. The effective closed-loop gain is being increased directly as R7 is made smaller, and the ratio of open-loop gain to closed-loop gain is becoming less. The gain and phase error of the filter at high Q is very dependent on the op amp open-loop gain at ω_0 .
3. The attenuation at extremes of frequency is limited by the op amp gain and unity-gain bandwidth. For integrators, the finite open-loop op amp gain limits the accuracy at the low-end. The open-loop roll-off of gain limits the filter attenuation at high frequency.

The RC4156 quad operational amplifier has much better frequency response than a conventional 741 circuit and is ideal for active filter use. Natural frequencies of up to 10 kHz are readily achieved and up to 20 kHz is practical for some configurations. Q can range up to 50 with very good accuracy and up to 500 with reasonable response. The extra gain of the RC4156 at high frequencies gives the quad op amp an extra margin of performance in active-filter circuits.

Schematic Diagram (1/4 shown)

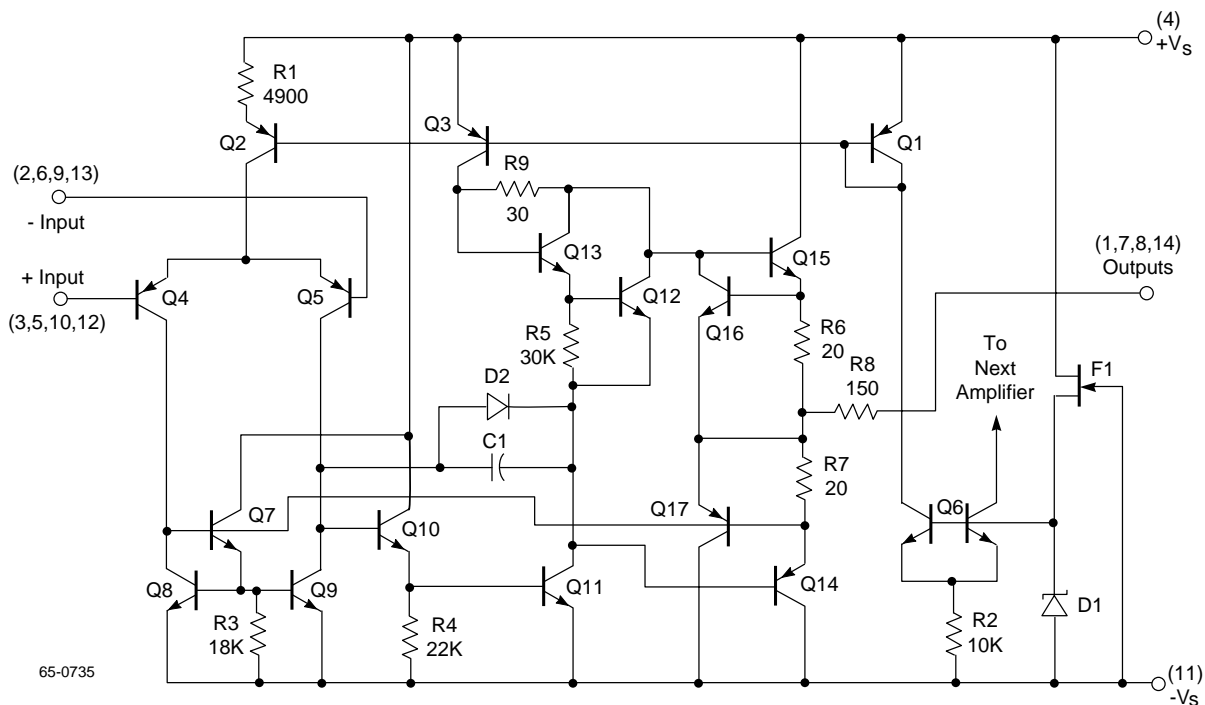

Mechanical Dimensions

14-Lead Ceramic DIP Package

Symbol	Inches		Millimeters		Notes
	Min.	Max.	Min.	Max.	
A	—	.200	—	5.08	
b1	.014	.023	.36	.58	8
b2	.045	.065	1.14	1.65	2
c1	.008	.015	.20	.38	8
D	—	.785	—	19.94	4
E	.220	.310	5.59	7.87	4
e	.100 BSC		2.54 BSC		5, 9
eA	.300 BSC		7.62 BSC		7
L	.125	.200	3.18	5.08	
Q	.015	.060	.38	1.52	3
s1	.005	—	.13	—	6
α	90°	105°	90°	105°	

Notes:

1. Index area: a notch or a pin one identification mark shall be located adjacent to pin one. The manufacturer's identification shall not be used as pin one identification mark.
2. The minimum limit for dimension "b2" may be .023 (.58mm) for leads number 1, 7, 8 and 14 only.
3. Dimension "Q" shall be measured from the seating plane to the base plane.
4. This dimension allows for off-center lid, meniscus and glass overrun.
5. The basic pin spacing is .100 (2.54mm) between centerlines. Each pin centerline shall be located within $\pm .010$ (.25mm) of its exact longitudinal position relative to pins 1 and 14.
6. Applies to all four corners (leads number 1, 7, 8, and 14).
7. "eA" shall be measured at the center of the lead bends or at the centerline of the leads when " α " is 90°.
8. All leads – Increase maximum limit by .003 (.08mm) measured at the center of the flat, when lead finish applied.
9. Twelve spaces.

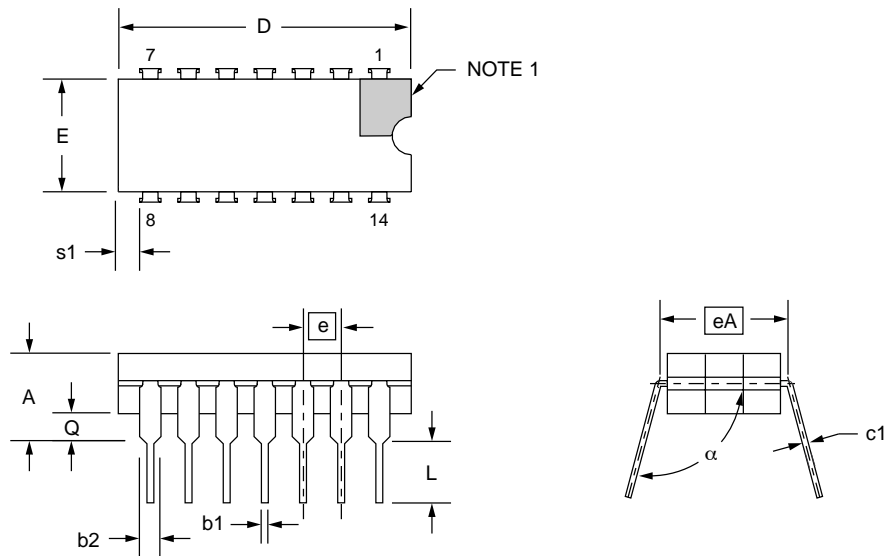

Mechanical Dimensions (continued)

14-Lead Plastic DIP Package

Symbol	Inches		Millimeters		Notes
	Min.	Max.	Min.	Max.	
A	—	.210	—	5.33	
A1	.015	—	.38	—	
A2	.115	.195	2.93	4.95	
B	.014	.022	.36	.56	
B1	.045	.070	1.14	1.78	
C	.008	.015	.20	.38	4
D	.725	.795	18.42	20.19	2
D1	.005	—	.13	—	
E	.300	.325	7.62	8.26	
E1	.240	.280	6.10	7.11	2
e	.100 BSC		2.54 BSC		
eB	—	.430	—	10.92	
L	.115	.200	2.92	5.08	
N	14		14		5

Notes:

1. Dimensioning and tolerancing per ANSI Y14.5M-1982.
2. "D" and "E1" do not include mold flashing. Mold flash or protrusions shall not exceed .010 inch (0.25mm).
3. Terminal numbers are shown for reference only.
4. "C" dimension does not include solder finish thickness.
5. Symbol "N" is the maximum number of terminals.

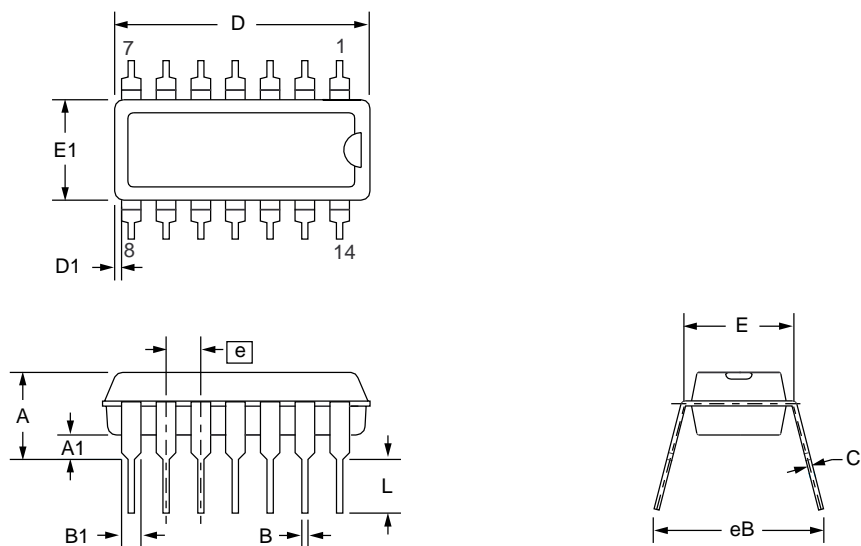

Mechanical Dimensions (continued)

14-Lead SOIC Package

Symbol	Inches		Millimeters		Notes
	Min.	Max.	Min.	Max.	
A	.053	.069	1.35	1.75	
A1	.004	.010	0.10	0.25	
B	.013	.020	0.33	0.51	
C	.008	.010	0.19	0.25	5
D	.336	.345	8.54	8.76	2
E	.150	.158	3.81	4.01	2
e	.050 BSC		1.27 BSC		
H	.228	.244	5.79	6.20	
h	.010	.020	0.25	0.50	
L	.016	.050	0.40	1.27	3
N	14		14		6
α	0°	8°	0°	8°	
ccc	—	.004	—	0.10	

Notes:

1. Dimensioning and tolerancing per ANSI Y14.5M-1982.
2. "D" and "E" do not include mold flash. Mold flash or protrusions shall not exceed .010 inch (0.25mm).
3. "L" is the length of terminal for soldering to a substrate.
4. Terminal numbers are shown for reference only.
5. "C" dimension does not include solder finish thickness.
6. Symbol "N" is the maximum number of terminals.

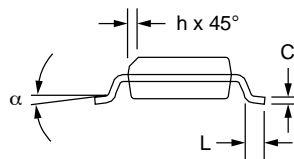
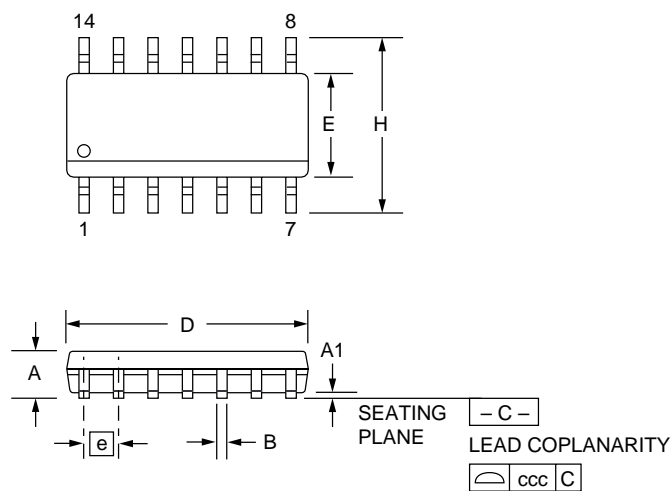

Ordering Information

Product Number	Temperature Range	Screening	Package	Package Marking
RC4156N	0° to 70°C	Commercial	14 Pin Plastic DIP	RC4156N
RC4157N	0° to 70°C	Commercial	14 Pin Plastic DIP	RC4157N
RC4156M	0° to 70°C	Commercial	14 Pin Wide SOIC	RC4156M
RC4157M	0° to 70°C	Commercial	14 Pin Wide SOIC	RC4157M
RM4156D	-55°C to +125°C	Commercial	14 Pin Ceramic DIP	RM4156DM
RM4156D/883B	-55°C to +125°C	Military	14 Pin Ceramic DIP	RM4156DMB

LIFE SUPPORT POLICY

FAIRCHILD'S PRODUCTS ARE NOT AUTHORIZED FOR USE AS CRITICAL COMPONENTS IN LIFE SUPPORT DEVICES OR SYSTEMS WITHOUT THE EXPRESS WRITTEN APPROVAL OF THE PRESIDENT OF FAIRCHILD SEMICONDUCTOR CORPORATION. As used herein:

1. Life support devices or systems are devices or systems which, (a) are intended for surgical implant into the body, or (b) support or sustain life, and (c) whose failure to perform when properly used in accordance with instructions for use provided in the labeling, can be reasonably expected to result in a significant injury of the user.
2. A critical component in any component of a life support device or system whose failure to perform can be reasonably expected to cause the failure of the life support device or system, or to affect its safety or effectiveness.